



GUARD-R

92 OLD BATHURST RD. EMU HEIGHTS NSW 2750, AUSTRALIA

PROJECT TITLE / PRODUCT TITLE

PROJECT OWNER / PRODUCT OWNER

GUARD-R

PRODUCT SPECIFICATIONS

FOOTING SPECIFICATIONS

ASSEMBLY COMPONENTS

NO.	DESCRIPTION	QTY
01	*****	*****
02	*****	*****
03	*****	*****
04	*****	*****
05	*****	*****
06	*****	*****
07	*****	*****
08	*****	*****
09	*****	*****
10	*****	*****

REVISIONS	
NO.	DESCRIPTION

FINISH DETAIL		WEIGHT	
MATERIAL GRADE	-----		
FIRST COATING TYPE	-----	COLOUR	-----
SECOND COATING TYPE	-----	COLOUR	-----
DRAWING TITLE	RMSPP0-I-BP	SHEET NO.	A 1.0
DATE	MAR 2023	SCALE	AS SHOWN
DRAWN BY	SUMMIT CAD	PAPER SIZE	A4
DESIGNED	SUMMIT CAD	PROJECT NO.	
APPROVED	STEVE G.	REF. NO.	
TOTAL SHEETS			2

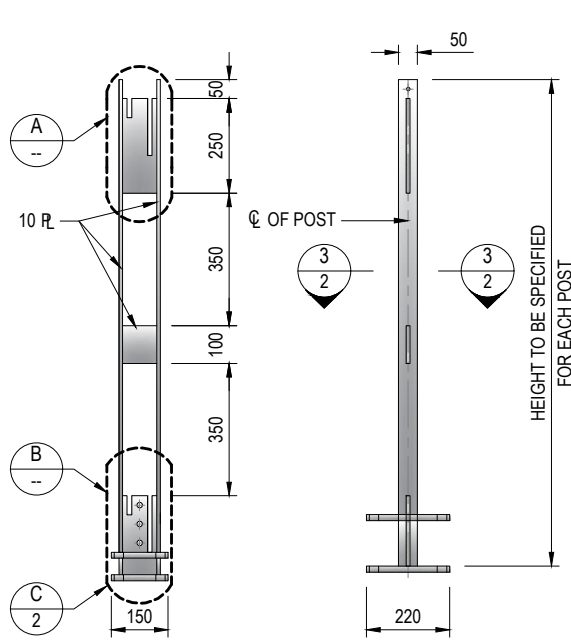

END ELEVATION
ELEVATION
INTERMEDIATE POST

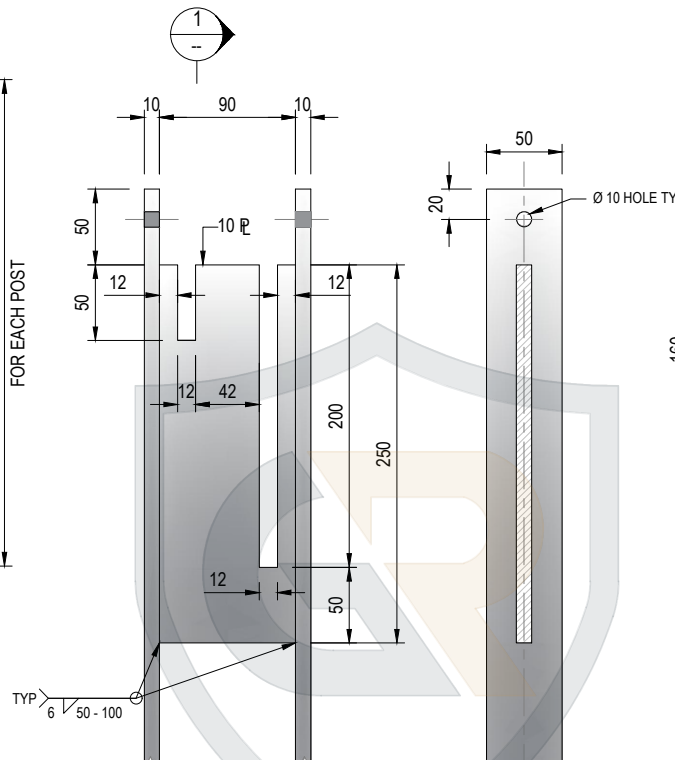
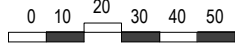

SECTION 1

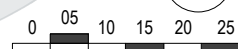

DETAIL A

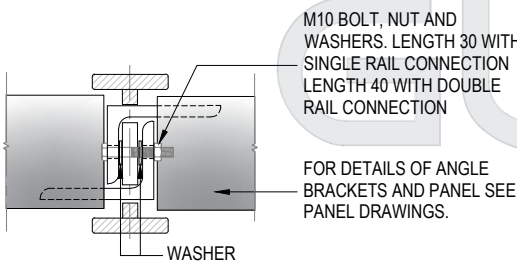

DETAIL OF BOTTOM RAIL CONNECTION

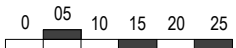

FENCE LIMITED TO GRADES OF UP TO 10%.

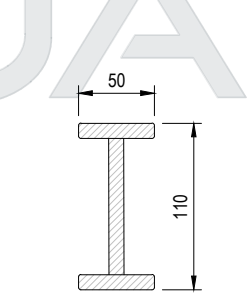

SECTION 2

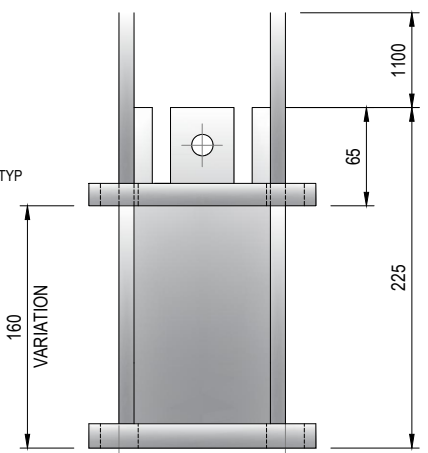
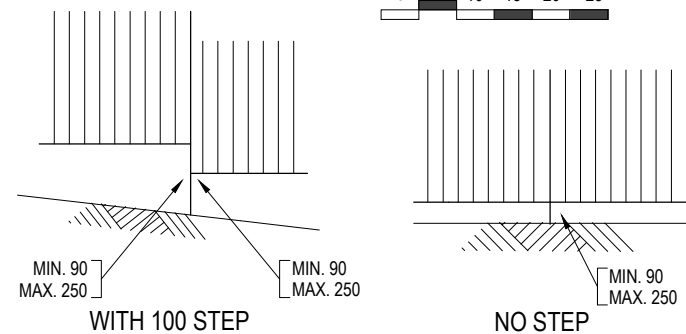
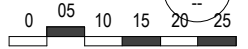

NO STEP

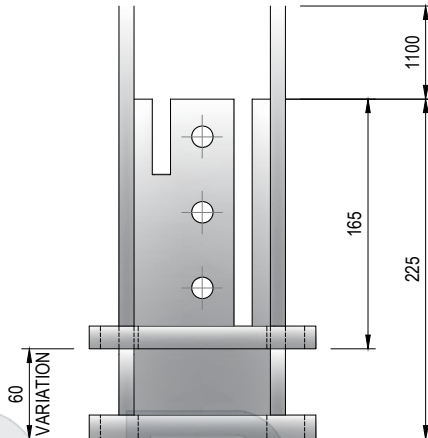

WITH 100 STEP

DETAIL B

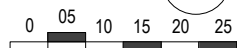

NOTE:

1. HEIGHT TO BE SUIT SITE CONDITION.
2. MINIMUM AND MAXIMUM HEIGHTS AS SHOWN IN DETAIL B, SHEET 1



GUARD-R

92 OLD BATHURST RD, EMU HEIGHTS NSW 2750, AUSTRALIA

PROJECT TITLE / PRODUCT TITLE

PROJECT OWNER / PRODUCT OWNER

GUARD-R

PRODUCT SPECIFICATIONS

FOOTING SPECIFICATIONS

ASSEMBLY COMPONENTS

NO.	DESCRIPTION	QTY
01	*****	*****
02	*****	*****
03	*****	*****
04	*****	*****
05	*****	*****
06	*****	*****
07	*****	*****
08	*****	*****
09	*****	*****
10	*****	*****

REVISIONS	
NO.	DESCRIPTION

FINISH DETAIL		-----
MATERIAL GRADE	-----	WEIGHT -----
FIRST COATING TYPE	-----	COLOUR -----
SECOND COATING TYPE	-----	COLOUR -----

DRAWING TITLE	RMSPP0-1-BP		SHEET NO.
DATE	MAR 2023	SCALE	AS SHOWN
DRAWN BY	SUMMIT CAD	PAPER SIZE	A4
DESIGNED	SUMMIT CAD	PROJECT NO.	-
APPROVED	STEVE G.	REF NO.	-
TOTAL SHEETS			2
SHEET NO.			A 2.0

